

CareCo **LIBRO**

▶ WATCH NOW

Scan me on your
phone camera
to watch our
assembly video.



USER MANUAL

PRODUCT CODE: MS01010037

For more products visit [careco.co.uk](https://www.careco.co.uk)

CareCo

INTRODUCING THE CARECO LIBRO MOBILITY SCOOTER

The CareCo Libro has been designed to provide a comfortable and safe solution for individuals that experience difficulty in walking.

Due to CareCo's commitment to continuous product improvement, product information and designs are subject to change without notice. No claims can be made based on the data and illustrations in this user manual.

The CareCo Libro Mobility Scooter is a Class I Medical Device: Class A Mobility Scooter, limited to a maximum speed of 4MPH.

It is the responsibility of the user and/or attendant to determine if they are mentally and physically capable of using the scooter safely. A risk assessment should be completed by a competent individual before operating the scooter.

The latest/current version of this user manual is available on our website.



CareCo (UK) Limited, 1 Turing Court,
Great Notley, Braintree, CM77 7AT

Tel: 0333 015 5000
www.CareCo.co.uk

Thank you for choosing CareCo.



This manual can be viewed in PDF format at the following URL: **www.careco.co.uk**

FIRST USE

- Read this user manual as well as any additional warnings/leaflets supplied.
- Take the time to understand the scooter's stopping duration, turning radius, throttle sensitivity and maneuverability.
- Operate the scooter at a low speed before gradually increasing to a higher speed.
- Practice using the scooter in an empty, open area until confident enough to operate in smaller and/or public areas.
- Keep this user manual in a safe place for future reference.

If any additional assembly, disassembly and/or operation assistance is required, please contact CareCo.

KEY DEFINITIONS

This user manual contains warnings and suggestions marked with the following symbols:



WARNING! Highlights a potentially hazardous condition/situation for the user and/or product.



SUGGESTION General suggestions and advice for operating the product.

Need help with assembly?

We've put together a step-by-step assembly guide to help you get your product set up safely and correctly. Just scan the QR code with your phone camera to play the video.

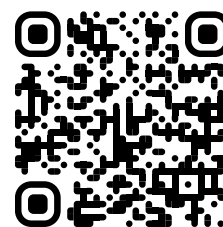

CONTENTS

GETTING STARTED _____	6
CARTON CONTENTS	
PRODUCT COMPONENTS	
SETTING UP YOUR CARECO LIBRO MOBILITY SCOOTER	
HOW TO USE YOUR MOBILITY SCOOTER _____	10
USER INSTRUCTIONS	
BRAKING TYPES	
DISCONNECTING & CONNECTING THE FRONT AND REAR SECTIONS	
TILLER CONTROLS	
CIRCUIT BREAKER	
SEAT	
BASKET	
MOBILITY SCOOTER MODES	
EMERGENCY BRAKING	
YOUR MOBILITY SCOOTER BATTERY _____	22
BATTERY INSTALLATION & REMOVAL	
BATTERY INFORMATION	
AUTOMATED POWER-SAVING	
CHARGING YOUR MOBILITY SCOOTER _____	23
HOW TO CHARGE YOUR SCOOTER	
CHARGING REGIME	
CHARGER INFORMATION	
DISASSEMBLING YOUR SCOOTER, TRANSPORTATION AND STORAGE _____	25
DISASSEMBLY INSTRUCTIONS	
UNFOLDING INSTRUCTIONS	
TRANSPORTATION & STORAGE _____	27
TRANSPORTATION	
STORING THE SCOOTER	

COMFORT ADJUSTMENTS	28
TILLER ANGLE ADJUSTMENT	
ARMREST WIDTH ADJUSTMENT	
SEAT HEIGHT ADJUSTMENT	
OPTIONAL EXTRAS	30
ESSENTIAL HARD CASE	
STAYCOSI WATERPROOF HEATED BLANKET	
LOOKING AFTER YOUR MOBILITY SCOOTER	31
CLEANING	
MAINTENANCE	
MAINTENANCE SCHEDULE	
REPAIRS	
TROUBLESHOOTING	34
WARNINGS & TECHNICAL INFORMATION	35
SCOOTER SPECIFICATIONS	
ELECTROMAGNETIC INTERFERENCE (EMI)	
PROGRAMMING	
PRODUCT RE-ISSUING	
RECYCLING & DISPOSAL	
INTENDED USE	
INTENDED ENVIRONMENT	
PRODUCT IDENTIFICATION	
GENERAL WARNINGS	
EXPECTED LIFETIME	40
WARRANTY	41
NOTES	42

GETTING STARTED

CARTON CONTENTS

ITEM NUMBER	DESCRIPTION	QUANTITY
1	CareCo Libro Mobility Scooter	1
2	Seat Assembly	1
3	Armrest Set	1
4	Armrest Bolt	2
5	Seat Post	1
6	Seat Post Pin	1
7	Seat Post Bolt	1
8	Battery Pack	1
9	Battery Securing Kit	1
10	Basket	1
11	Charger	1



We strongly recommend that you keep the box and internal packaging for the duration of your warranty period.

PRODUCT COMPONENTS



1. Tiller Control Panel
2. Basket
3. Tiller Angle Adjustment Knob
4. Armrest
5. Seat
6. Battery Pack
7. Drive/Freewheel Lever
8. Rear Wheel
9. Front Wheel
10. Front Bumper

SETTING UP YOUR CARECO LIBRO MOBILITY SCOOTER



1. Remove all scooter components from the outer packaging, then place them onto a level surface.

2. Loosen the tiller knob, then lift the tiller upwards.

Tighten the tiller knob to secure the position.



3. Place the battery pack into the battery tray.

4. Secure the battery position using the battery securing kit provided.



5. Insert the seat post into the scooter base.



6. Insert the seat post pin to secure the seat post height.



7. Insert the seat post bolt to secure the seat post position.



8. Lower the seat onto the seat post.



9. Insert the armrests into the lower seat bracket, then secure using the armrest bolts provided.



10. Press & hold the basket holder latch, then hook the basket onto the holder.

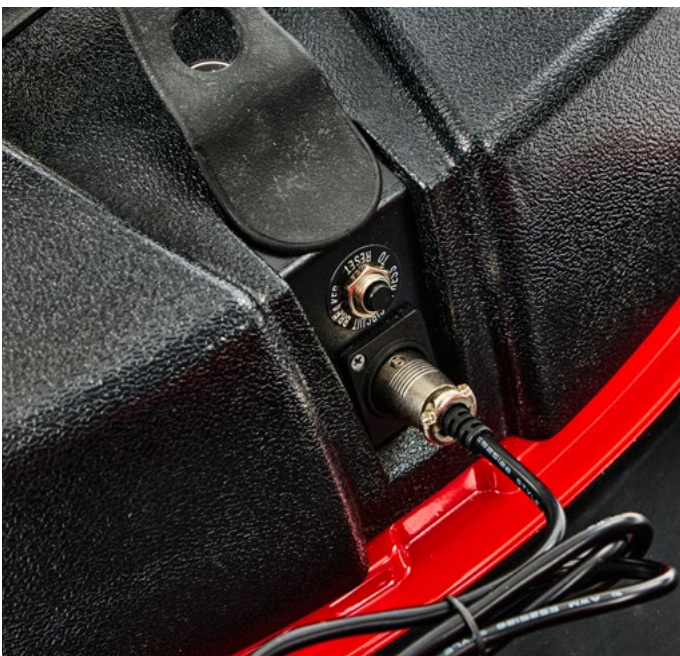

11. Charge the scooter for 12-16 hours before first use.



SUGGESTION Subsequent charging times range from 8-12 hours. Visit "Charging your Mobility Scooter" for more information.

HOW TO USE YOUR MOBILITY SCOOTER

USER INSTRUCTIONS

TRANSFERRING TO & FROM

There are two methods for users to get on/off of the mobility scooter safely.

Always ensure the scooter is switched [OFF] and in [DRIVE] mode before getting on/off the scooter.

METHOD 1

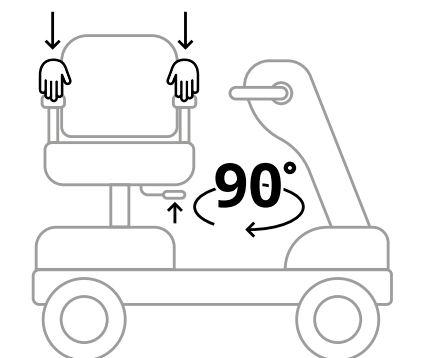

TRANSFERRING TO

1. Lift the seat lever, then rotate the seat 90° away from the tiller.
2. Support your body using the armrests, before lowering into the seat.
3. Lift the seat lever, then rotate your body towards the tiller.
4. Release the seat lever to secure the position.

TRANSFERRING FROM

1. Lift the seat lever, then rotate the seat 90° away from the tiller.
2. Support your body using the armrests, then place your feet firmly on the ground.
3. Push upwards to lift out of the seat.
4. Lift the seat lever, then rotate the seat towards the tiller.
5. Release the seat lever to secure the position.

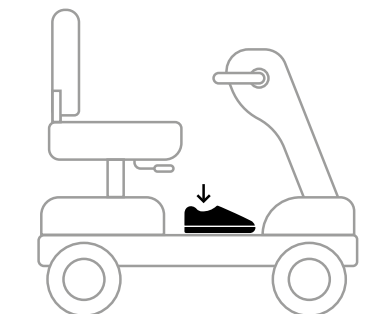
METHOD 2**TRANSFERRING TO**

1. Lift the scooter armrest(s) upwards.
2. Support your body by placing one foot on the scooter footplate, then lower into the seat.
3. Lower the armrest(s) into the resting position.

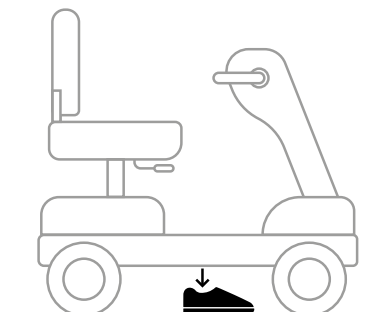
**TRANSFERRING FROM**

1. Lift the scooter armrest(s) upwards.
2. Support your body by placing one foot on the ground, then lift out of the seat.
3. Lower the armrest(s) into the resting position.

GRADIENTS**ASCENDING GRADIENTS**

Tilt your upper body forward when travelling up gradients for increased stability.

**DESCENDING GRADIENTS**

Tilt your upper body back when travelling down gradients for increased stability.

The maximum safe slope of incline is 6°.

THRESHOLDS & FIXED OBSTACLES

Approach thresholds vertically to avoid scooter misbalance.

Incorrect Approach

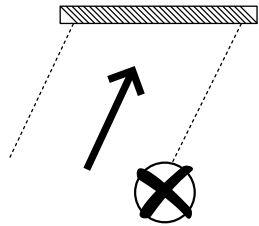

Correct Approach

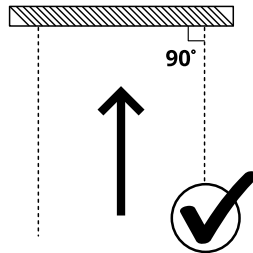

STAIRS, ESCALATORS AND LIFTS

The mobility scooter is not designed to travel up/down stairs and escalators. Use a lift whenever possible.

DOORS & GATES

Determine whether the door/gate opens towards or away from the user.

Reach for the handle and carefully accelerate forwards or backwards depending on the door/gate orientation.

CORNERING

Approach corners at a speed that the user feels comfortable and in control of. If at any point the user feels like the scooter may tip, reduce the scooter speed and steering angle.

BRAKING TYPES

REGENERATIVE BRAKING

- Slows the scooter when the throttle returns to the centre position
- Slows the scooter when the speed limiter is exceeded

PARKING BRAKE

- Activates after the scooter has come to a stop.
- Activates when the product is in [DRIVE] mode and is powered [OFF].

BRAKING DISTANCE

On flat surfaces, braking distance is approximately equal to the length of the scooter. Braking distance may increase when travelling downhill.

DISCONNECTING & CONNECTING THE FRONT AND REAR SECTIONS

The CareCo Libro scooter sections arrive pre-assembled but can be disassembled to assist the user when travelling and storing.

The below instructions demonstrate the step-by-step method of disconnecting and connecting the scooter sections.

! **WARNING!** Ensure the scooter is switched [OFF] and in [DRIVE] Mode before disassembling.

DISCONNECTING



1. Lift the seat upwards to remove it from the scooter.



2. Loosen OR remove the battery securing kit.



3. Remove the battery pack from the battery tray.

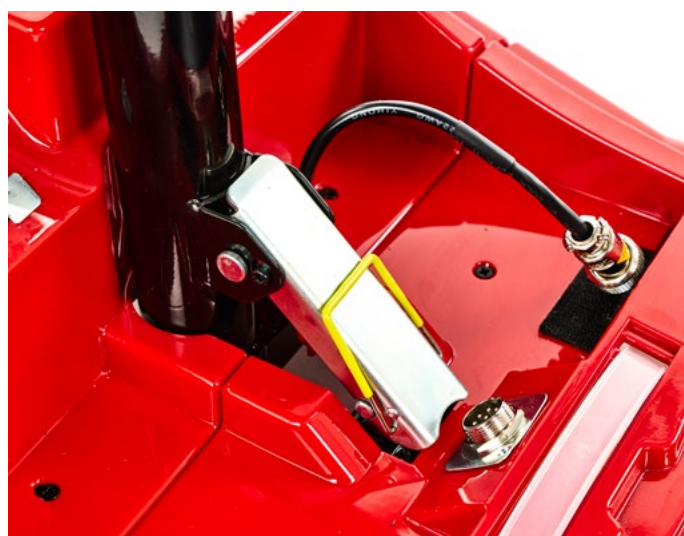

4. Loosen the lock nut, then disconnect the power cable.



5. Pull the yellow latch upwards to unlock the front & rear sections.



6. Hold the seat post and footplate, then lift the sections away from each other.



7. Transport/store the scooter sections.

CONNECTING



1. Rest the rear section on its carry handle, then place the front section adjacent to the rear section.

2. Lift the footplate handle, then locate the front section hooks onto the rear section bar.



3. Tilt the rear section forwards until the seat post is vertical.

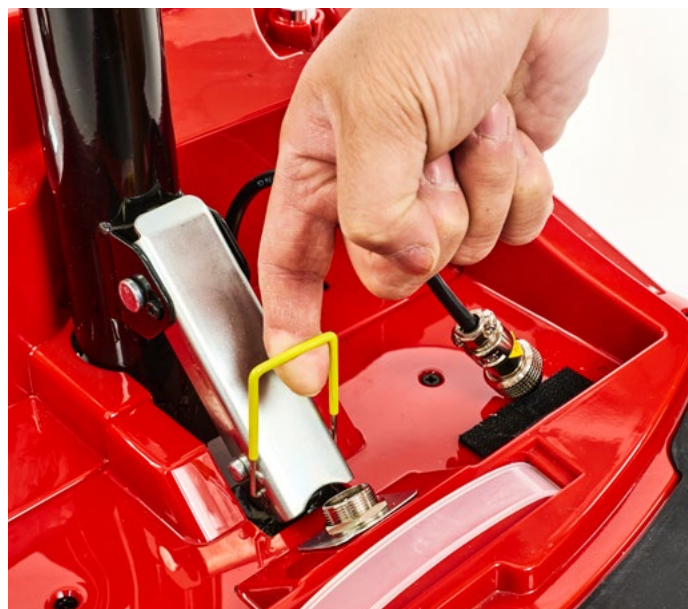

4. Lift the yellow latch onto the battery tray hook.

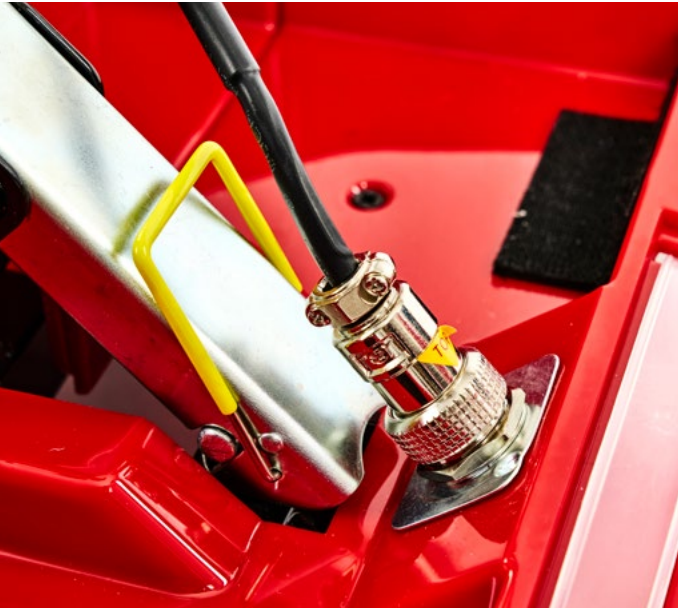

5. Connect the power cable, then tighten the lock nut.
6. Reinstall the battery pack and seat.





WARNING! Beware of pinch points when disconnecting/connecting the scooter sections. Ensure all scooter sections and connections are secure before use.

TILLER CONTROLS



KEY SWITCH 
Insert/extract the key to activate or deactivate the scooter.

SPEED DIAL 
Turn the dial clockwise to increase the scooter's speed setting.
Turn the dial anticlockwise to decrease the scooter's speed setting.

BATTERY GAUGE 
Displays the battery level status.

GREEN The battery is fully charged.

YELLOW The battery is near/at half capacity.

RED The battery is low and should be charged soon.

THROTTLE LEVER 
Using your right hand, press the throttle lever to move the scooter forwards. Using your left hand, press the throttle lever to move the scooter backwards.

When the lever is released, it will return to the centre, and the scooter brake will automatically engage.

CIRCUIT BREAKER

The battery pack is equipped with a circuit breaker to protect the motor and other components in case of a power overload. If the scooter overloads, the scooter will power off.

To reactivate the scooter:

1. Switch [OFF] the scooter.
2. Wait for 60 seconds.
3. Press and hold the breaker for up to 5 seconds.
4. Switch [ON] the scooter.



SEAT

ATTACHING

Lower the seat onto the seat post.

REMOVING

Lift the seat upwards to remove it from the scooter.

SWIVEL

Lift & hold the lever whilst rotating the seat.

Release the lever to secure the position.



WARNING! Take extra care when attaching/removing the scooter seat to prevent product damage and personal injury.

BASKET

Press & hold the basket holder latch, then hook/unhook the basket.

Use the baskets built in carry handle to transport items to/from the scooter.



MAX CARRY WEIGHT: 5KG



WARNING! Do not exceed the maximum carry weight.

MOBILITY SCOOTER MODES



DRIVE MODE

(ELECTRONIC ASSISTED BRAKING)

Pull the lever backwards to engage Drive Mode.

(The scooter will not be able to be pushed manually by the user).



FREEWHEEL MODE

Push the lever forwards to engage Freewheel Mode.

(The scooter will be able to be pushed manually by the user).

 **WARNING!** Do not change the scooters mode whilst on an incline.

 **SUGGESTION** Switching [ON] the scooter whilst in freewheel mode will activate the scooters automatic warning function.

EMERGENCY BRAKING

Switch [OFF] the scooter whilst moving to come to an emergency stop.

 **WARNING!** This method is for emergency situations only.

Repeated use of the [ON/OFF] switch to stop the scooter may shorten the life of the scooter's components.

YOUR MOBILITY SCOOTER BATTERY

BATTERY INSTALLATION & REMOVAL



INSTALLING

Place the battery pack into the battery tray, then secure the position using the battery securing kit provided.



REMOVING

Loosen OR remove the battery securing kit, then lift the battery pack away from the scooter.

BATTERY INFORMATION

BATTERY TYPE	Sealed Lead Acid
SPILLABLE/NON-SPILLABLE	Non-Spillable
VOLTAGE	12v
AMPAGE	12Ah
QUANTITY	2
WATT HOURS	244Wh



WARNING! Ensure the scooter is switched [OFF] whenever installing or removing the battery pack.

AUTOMATED POWER-SAVING

The scooter will automatically power [OFF] if no movement is detected for 20 minutes.

To reactivate the scooter, switch the scooter [OFF/ON].

CHARGING YOUR MOBILITY SCOOTER

Your CareCo Libro battery pack can be charged on or away from the scooter if required.

To charge the battery pack away from the scooter, remove it following the instructions found in this user manual, before continuing with the instructions below.

1. Lift the front cover on the battery pack to reveal the charge socket.
2. Insert the charger's 3-pin output into the socket on the battery pack.
3. Insert the outlet plug into a wall socket.
4. Switch [ON] the wall socket.
5. Charge for 8-12 hours.

When charging is completed, switch [OFF] the wall socket, remove the outlet plug, then remove the charger from the battery pack.



WARNING! Ensure the scooter is switched [OFF] whenever charging the battery pack.

CHARGING REGIME

Maintaining good charging habits for your scooter will maximize battery life and range per charge.

Battery charging times range from 8-12 hours. This is dependent on scooter usage, ambient temperature, and operating habits.

Daily Use	If the scooter is used daily, charge the battery at the end of each day for 8-12 hours.
Weekly Use	If the scooter is used once or twice a week, charge the battery for at least 8-12 hours once a week.
Monthly Use	If the scooter is stored for long periods of time, preserve the life of the battery by charging once every two weeks for 8-12 hours.



SUGGESTION The charging information provided is to be used as a general guide. Increased/decreased scooter usage may require more/less frequent charging.

CHARGER INFORMATION

The battery charger is fitted with a smart LED indicator that indicates when the battery is charging and when charging is complete.

LED Indicator	Charging Status
---------------	-----------------

 GREEN	Charged
--	---------

 BLUE	Charging
---	----------



WARNING! Do not use the supplied charger with any other electrical device.
Only charge the scooter with the supplied charger or an official replacement.
Do not leave the scooter on charge indefinitely.



SUGGESTION Charge the battery in a cool, dry place with plenty of ventilation.

DISASSEMBLING YOUR SCOOTER, TRANSPORTATION AND STORAGE

DISASSEMBLY INSTRUCTIONS

 **WARNING!** Ensure the scooter is switched [OFF] and in [DRIVE] Mode before disassembling.



1. Press & hold the basket holder latch, then unhook the basket.



2. Lift the seat upwards to remove it from the scooter.



3. Loosen OR remove the battery securing kit, then lift the battery pack away from the scooter.

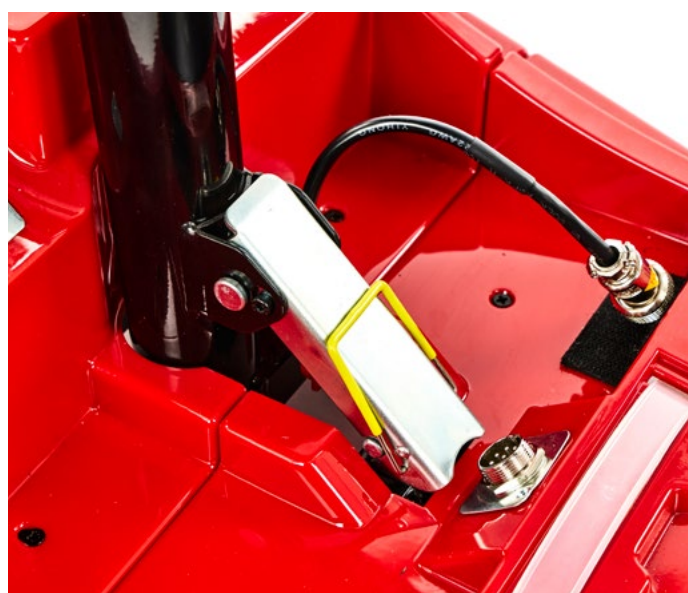

4. Loosen the lock nut, then disconnect the power cable.



5. Pull the yellow latch upwards to unlock the front & rear sections.



6. Hold the seat post and footplate, then lift the sections away from each other.



7. Loosen the tiller knob, then lower the tiller.

Tighten the tiller knob to secure the position.



8. Transport/store the scooter sections.

TRANSPORTATION

LAND TRANSPORT

Securely stow the folded/disassembled components in the boot of a vehicle.

Ensure any adjustable parts are properly secured before transport to avoid transit damage.



WARNING! This product cannot be used as a seat in a motor vehicle.



AIR TRANSPORT

This scooter is suitable for air transport. Prior to your journey, contact your airline in advance to confirm their flight-specific requirements.

STORING THE SCOOTER

SHORT TERM STORAGE

Store the scooter in a cool and dry environment. Do not store in extreme temperatures.

LONG TERM STORAGE

Fully charge the battery before long term storage.

Store the scooter in a cool and dry environment. Do not store in extreme temperatures.

Charge the battery once every two weeks to preserve the life of the battery.

STORAGE TEMPERATURE

-40°C to 65°C



WARNING! Storing the scooter in extreme temperatures can cause premature rusting & damage to the scooters electronic system.

COMFORT ADJUSTMENTS

TILLER ANGLE ADJUSTMENT

1. Loosen the tiller knob by twisting it anticlockwise.
2. Lift or lower the tiller until it is in a suitable and comfortable position.
3. Tighten the tiller knob by twisting it clockwise.



 **WARNING!** Ensure the tiller is secure before using the scooter.

ARMREST WIDTH ADJUSTMENT

1. Loosen the armrest knob by rotating it anticlockwise.
2. Move the armrest outwards/inwards until it is in a suitable and comfortable position.
3. Tighten the armrest knob by rotating it clockwise.
4. Repeat on the opposite side.



 **WARNING!** Ensure the armrests are an equal distance apart and are secure before using the scooter.

SEAT HEIGHT ADJUSTMENT

1. Remove the seat following the instructions found within this user manual.
2. Loosen the seat post knob and remove the pin.
3. Lift/lower the seat post until it is at a suitable height.
4. Insert the pin and tighten the seat post knob to secure the position.
5. Place the seat onto the seat post.



 **WARNING!** Ensure the seat post & seat are secure before use.

OPTIONAL EXTRAS

ESSENTIAL HARD CASE

Designed for most travel scooters and powerchairs, the Essential Hard Case keeps your belongings safe and secure whilst out and about.

Contact CareCo for more information.



STAYCOSI WATERPROOF HEATED BLANKET

The StayCosi Waterproof Heated Blanket is the perfect accompaniment when out and about on your Mobility Scooter.

Contact CareCo for more information.



LOOKING AFTER YOUR MOBILITY SCOOTER

CLEANING

Clean the scooter at regular intervals to prevent poor driving performance, and unwanted dirt build up. Use the guides below to keep the scooter in showroom condition for years to come.

The images provided are for visual reference only.

QUICK CLEAN (RECOMMENDED AFTER EACH JOURNEY)



You will need:

Hand Towel

Soft Bristle Brush

1. Loosen any dirt/debris from the scooter using a soft bristle brush.
2. Wipe over the scooter with a hand towel/microfibre cloth.



SUGGESTION Regular cleaning & maintenance can help prolong the scooters lifespan.

DEEP CLEAN (RECOMMENDED MONTHLY)



You will need:

Hand Towel

Soft Bristle Brush

Sponge

Mild Soap/Detergent

Bucket

1. Loosen any dirt/debris from the scooter using a soft bristle brush.
2. Add a small amount of soap/detergent to a bucket, then fill it with warm water.
3. Dip the sponge into the soapy water, then wring it out until damp.
4. Wipe over the product from top to bottom with the sponge.
5. Empty the bucket and refill it with warm water.
6. Dip the sponge into the water and wring it out until damp.
7. Wipe down the product from top to bottom with the sponge to remove any soapy residue.
8. Dry the product thoroughly with a hand towel/microfibre cloth.



WARNING! Do not use bleach or strong chemicals to clean the scooter.

Ensure the scooter is switched [OFF] and disconnected from the mains prior to cleaning.

MAINTENANCE

Your scooter is made up of components which over time will become susceptible to wear and tear.

Knowing how to properly care and maintain your scooter will not only ensure peak performance and safe operation but will also help to maintain operation for years to come.

MAINTENANCE SCHEDULE

Carry out regular inspections to keep the scooter in optimum condition.

COMPONENT	INSPECTION DESCRIPTION	AT ANY TIME	WEEKLY	MONTHLY	QUARTERLY
TILLER CONTROLS	Ensure the tiller controls function as intended.	○			
DRIVE/BRAKE SYSTEM	Ensure the scooter moves normally and the brake is responsive.	○			
CONNECTIONS	Ensure the scooter connections are free from damage and corrosion.	○			
TYRES	Ensure tyres have sufficient tread and are in a good condition.				○
FRAMEWORK	Ensure the framework is clear from debris and damage.	○			
FASTENERS	Ensure all fasteners are tight and components are not loose.			○	
WHEELS	Ensure the wheels are aligned and drive straight.				○
UPHOLSTERY	Check for wear and tear.		○		
OVERALL	Overall check for wear and residue build-up. Cleaning if required.			○	

REPAIRS

Certain scooter components can be repaired by the user with guidance provided by CareCo.

Other components can only be repaired/replaced by a service technician.

If for any reason the scooter requires repair due to a defect, contact CareCo immediately.

TROUBLESHOOTING

Your CareCo Libro features an automatic fault warning function. If there is an internal issue with the scooter, the tiller display will flash, and the horn will sound.

FLASH CODE	POSSIBLE CAUSE	POSSIBLE REMEDY
1 FLASH CODE	The battery voltage is too low.	Charge the battery for 8-12 hours.
	The battery and/or its associated wiring has a fault.	Ensure the battery pack is secure and there is nothing blocking the battery contacts.
		Contact CareCo.
2 FLASH CODE	The motor and/or its associated wiring has a fault.	Contact CareCo.
3 FLASH CODE	The motor has overheated.	<ol style="list-style-type: none"> 1. Switch [OFF] the scooter. 2. Wait for 10 minutes. 3. Switch [ON] the scooter.
	The motor and/or its associated wiring has a fault.	Contact CareCo.
4 FLASH CODE	N/A	4. N/A
5 FLASH CODE	The scooter is in [FREEWHEEL] mode.	<ol style="list-style-type: none"> 1. Switch [OFF] the scooter 2. Place the scooter in [DRIVE] mode. 3. Switch [ON] the scooter.
	The brake and/or its associated wiring has a fault.	Contact CareCo.
6 FLASH CODE	The charger is connected to the scooter.	<ol style="list-style-type: none"> 1. Switch [OFF] the scooter. 2. Disconnect the charger. 3. Switch [ON] the scooter.
7 FLASH CODE	The throttle lever is being obstructed.	<ol style="list-style-type: none"> 1. Switch [OFF] the scooter 2. Release the throttle lever obstruction 3. Switch [ON] the scooter.
	The throttle and/or its associated wiring has a fault.	Contact CareCo.
	The speed potentiometer and/ or its associated wiring has a fault.	Contact CareCo.
8 FLASH CODE	The controller and/or its associated wiring has a fault.	Contact CareCo.
9 FLASH CODE	The scooter is in [FREEWHEEL] mode.	<ol style="list-style-type: none"> 1. Switch [OFF] the scooter. 2. Place the scooter in [DRIVE] mode. 3. Switch [ON] the scooter.
	The brake and/or its associated wiring has a fault.	Contact CareCo.
10 FLASH CODE	The battery voltage is too high.	<ol style="list-style-type: none"> 1. Wait for 60 seconds. 2. Lift the rubber cover on the battery pack to reveal the circuit breaker. 3. Press and hold the breaker for up to 5 seconds. 4. Switch [ON] the scooter.



SUGGESTION It is normal for the scooter to make audible noise whilst in use, if you notice an unusual noise, contact CareCo.

WARNINGS & TECHNICAL INFORMATION

SPECIFICATIONS

OVERALL LENGTH (MM)	1030
OVERALL WIDTH (MM)	520-650
OVERALL HEIGHT (MM)	840
FOLDED LENGTH (MM)	1030
FOLDED WIDTH (MM)	500
FOLDED HEIGHT (MM)	430
FRONT WHEEL DIAMETER (IN)	8
REAR WHEEL DIAMETER (IN)	8
TOTAL WEIGHT INCLUDING BATTERIES (KG)	40
WEIGHTS OF FRONT & REAR SECTIONS (KG)	FRONT: 12.3 REAR 13.2
MAXIMUM SPEED (MPH)	4
MAXIMUM REVERSE SPEED (MPH)	2
REVERSING WIDTH (MM)	1600
WEIGHT CAPACITY (KG)	120
GROUND CLEARANCE (MM)	50
MAXIMUM CLIMBABLE ANGLE (°)	6
CURB HEIGHT CLIMBABLE (MM)	40
TURNING RADIUS (MM)	1400
SUSPENSION (YES/NO)	NO
SEAT HEIGHT OPTIONS (MM)	460/495/530
SEAT WIDTH (MM)	400
SEAT DEPTH (MM)	350
SEAT WEIGHT (KG)	6.55
BATTERY SPECIFICATION	12V 12AH X2
MOTOR SPECIFICATION	24V180W
CONTROLLER SPECIFICATION	PG 45A
OFF BOARD CHARGING (YES/NO)	YES
BATTERY WEIGHT (KG)	8.9
MAXIMUM POTENTIAL RANGE (KM)	20
STOPPING DISTANCE FROM MAX SPEED (MM)	1000
MOISTURE RESISTANCE	IPX4
MAX/MIN OPERATING TEMPERATURE (°)	65°C / -25°C
MAX/MIN STORAGE TEMPERATURE (°)	65°C / -40°C
TYRE TYPE	SOLID
VM RESISTANCE RATING (EM IMMUNITY)	20
HANDLEBAR DIAMETER (MM)	35

The maximum weight limit includes both the user and any other accessories fitted to the scooter.

Due to manufacturing tolerances and continued product improvement, this specification can be subject to a variance of (+ or -) 3%.

ELECTROMAGNETIC INTERFERENCE (EMI)

Powerchairs and mobility scooters may be susceptible to electromagnetic interference (EMI).

Electromagnetic energy (EM) is emitted from sources such as radio stations, TV stations, amateur radio (HAM) transmitters, two-way radios, and cellular phones.

The interference (from radio wave sources) can cause the powerchair/mobility scooter to release its brakes, move by itself, or move in unintended directions. It can also permanently damage the powerchair/mobility scooter's control system.

Each powerchair/mobility scooter can resist EMI up to certain intensity. The intensity of the interfering EM energy can be measured in volts per meter (V/m).

If the scooter is operating abnormally, turn off the scooter and/or the equipment that is believed to be causing the interference.



WARNING! Do not operate portable personal communication devices, such as citizen band (CB) radios and mobile phones when the scooter is powered [ON].

If use of a personal communication device is required, ensure the scooter operates as intended.

Avoid using the scooter near transmitters, such as radio or television stations.

Adding unauthorised accessories, parts, or modification can make the scooter more susceptible to interference from radio wave sources.

The immunity level of this mobility scooter is 20 V/m.

PROGRAMMING

The scooter can be programmed using computer-based software and/or using a handheld programming device.

Programming should only be completed by a qualified service technician. Unauthorised modifications will affect driving performance and other parameters.

PRODUCT RE-ISSUING

Ensure the product is safe and functions as intended before re-issuing.

RECYCLING & DISPOSAL

Scooter components should not be disposed of with normal household waste as they can cause harm to the environment.

When disposing of the scooter and/or its components, users should follow Waste Electrical and Electronic Equipment policies (W.E.E.E).

For battery disposal, users should follow local disposal/recycling regulations.

Contact CareCo if further advice is needed regarding recycling & disposal.

INTENDED USE

This product is intended for users who experience difficulty in walking and/or have reduced mobility.

INTENDED USER

To aid a user with mobility limitations to move around independently and safely.

INTENDED ENVIRONMENT

This scooter is designed to be used both indoors and outdoors on firm, level ground. Take care when using the scooter in inclement weather conditions.

PRODUCT IDENTIFICATION

The product identification label is located in the battery tray.

CareCo Libro Mobility Scooter **MD** Mobility Scooters

REF MS01010037 **UDI** 



SN 6 978949 462484

 Zhejiang Innuovo Rehabilitation Devices Co Ltd, No. 196 Industry Road, Hengdian Movie Zone, Dongyang, Zhejiang, China PO NUMBER:

 CareCo, 1 Turing Court, Great Notley, Braintree, Essex, CM77 7AT **W3431**













EC REP SUNGO Europe B.V., Fascinatio Boulevard 522, Unit 1.7,2909VA Capelle aan den IJssel, The Netherlands 

UK REP Sungo Certification Company Limited, 3rd Floor, 70 Gracechurch Street, London, EC3V 0HR, England 

 

 **Max User Weight: 120 KG**

DEFINITIONS

	Model number		Refer to instruction manual
	Batch code		Caution
	Date of manufacturer		Indicates electrical / electronic equipment must be disposed of in accordance with the WEEE regulation.
	Manufacturer's address		Keep away from rain
	Product expiry date		Keep away from sunlight
	UK responsible person		
	UKCA Mark		
	Non sterile		

GENERAL WARNINGS

- Mobility Scooter users should take appropriate safety measures and obey local pedestrian traffic rules. CareCo are not responsible for personal injury and/or product damage caused by improper use.
- Use safety equipment such as reflectors, reflective clothing, and lighting when in low lit areas.
- Please consult a healthcare professional regularly to ensure that there are no health/physical conditions that limit or compromise the user's safety when using the scooter.
- If the user is taking over-the-counter medications, prescriptions or if physical activity is limited, please consult a physician. Some medications and medical conditions may limit the user's ability to operate the scooter.
- Do not operate the scooter after consuming alcohol as this can affect the safe operation of the scooter.
- Do not use the scooter for any other purpose other than its intended use. Incorrect use of the scooter can cause a safety hazard to the product and the user.
- This scooter is intended for one user at a time. Do not exceed the maximum load weight of 120kg.
- Do not place the scooter in FREEWHEEL mode when on an incline.
- Turn the scooter [OFF] when sat in a fixed position for extended periods of time.
- Avoid using accessories that could interfere with the safe operation of the throttle.
- Do not alter the products wiring.
- Keep body, clothing, and any other objects away from moving parts to avoid trap hazards.
- Prolonged storage at low or high temperatures can damage the scooter.
- Do not transport the scooter or battery with combustible materials.
- This product cannot be used as a seat in a motor vehicle. 
- Ensure the scooter is in Drive mode before operating.
- Be aware of surroundings at all times when using the scooter.

EXPECTED LIFETIME

The Expected Lifetime is the estimated period of time for which the scooter is expected to function according to its intended use.

Various items such as weight capacity, user behaviour, external conditions and intensity of use can affect the expected lifetime.

WEIGHT CAPACITY:

If the user exceeds the weight limit specified, it may affect the scooter's expected lifetime.

USER BEHAVIOUR:

Using excessive force, rough handling or dropping components can significantly shorten the scooter's expected lifetime.

EXTERNAL CONDITIONS:

Extreme temperatures, humidity and exposure to harsh weather conditions can accelerate the deterioration of the scooter.

USAGE:

A scooter that is used daily may experience more wear and tear compared to a scooter that is used occasionally.

The expected lifetime for the scooter is 5 years providing the instructions and information within this user manual are followed.

Regular cleaning, lubrication of moving parts, and tightening of loose fixings will prevent premature wear and damage and extend the product's lifetime.

The expected lifetime is not related to the product warranty.

WARRANTY

If a component requires repair or replacement due to a specific manufacturing or material defect within its warranty period, it will be repaired or replaced free of charge by CareCo.

- **FRAME: 5-YEAR LIMITED WARRANTY**
- **ELECTRONIC COMPONENTS: 1-YEAR LIMITED WARRANTY**
- **BATTERY: 6-MONTH LIMITED WARRANTY**

Consumables are not covered under normal warranty circumstances unless they have clearly suffered excessive wear or damage as a direct result of a manufacturing defect. These items include grips, tyres, and rubber accessories.

The guarantee for the scooter is not transferable.

Parts that have been previously replaced that require subsequent repair or replacement due to manufacturing defects will be honoured for the remainder of the scooter's warranty period.

Parts that have been purchased by the end user after the original warranty period has expired have a warranty period of 12 months.

CareCo is not responsible if the scooter requires repair or replacement as a direct result of:

- Changes or modifications made to the product that fall outside of the manufacturer's specifications.
- The product not being serviced or maintained according to the manufacturer's recommendations contained in this user manual.
- Negligence, Accidental Damage, and Improper use.
- Repairs attempted before CareCo have been notified.
- The product being purposely damaged or mistreated.

In the unlikely event that this product is recalled, CareCo will notify the user.

Please ensure that your contact information is up to date.

Alternatively, please visit our website for any product alerts: www.CareCo.co.uk

NOTES

NOTES



CareCo (UK) Limited, 1 Turing Court,
Great Notley, Braintree, CM77 7AT

2512-07

Tel: 0333 015 5000
www.CareCo.co.uk