



LED Table Lamp

Product Code: RR07124

Before You Begin

- Unpack all components onto a flat surface that will not damage them or allow them to become dirty.
- Check that all components are correct and present.
- Familiarise yourself with the product, its component parts and how it is assembled.
- Keep all packaging until after a successful installation and retain the instructions for future reference.

Safety Notes

- This product is intended for indoor use only
- Ensure that the lamp is used on a flat stable surface and that the cable is sited in a way that will not cause a tripping hazard
- Do not allow the lamp to be covered, ensure that curtains, drapes etc. do not cover the lamp.

Assembly Instructions

1. Remove any additional packaging
2. Place lamp base (A) on a stable, flat, dry surface.
3. Insert the plug (B) into an outlet.
4. To avoid tipping the lamp over, do not bend the lamp head completely backwards.
5. Use the HIGH (II)- OFF(O)- LOW (I) switch (D) on lamp shade to turn lamp on and off.
6. The SMD type LED supplied is solid state and is not intended to be replaced

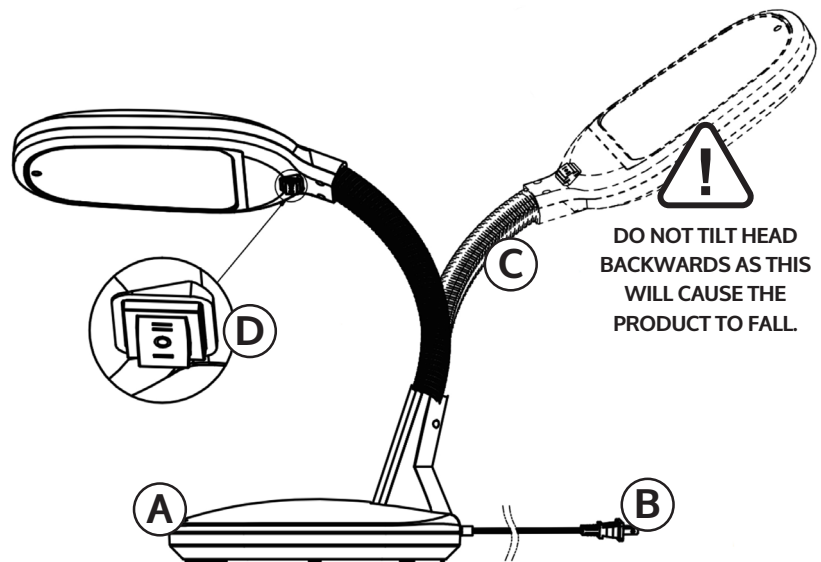

Care & Use

- Only clean with a clean dry cloth, to prevent damage to the plated / painted finish.
- If the external cable or cord becomes damaged, it shall be replaced by the manufacturer, its service agent or similar qualified person in order to prevent a hazard.

Warranty

Your CareCo branded product is under warranty to be free from defects in material and workmanship for one year from date of receipt. This warranty expresses our confidence in the workmanship and materials used for our products.

In the event of a defect covered by this warranty, CareCo will, at our discretion, replace the product or supply parts to remedy. This warranty does not cover device failure due to owner misuse or negligence, or due to normal wear and tear. The warranty does not extend to non-durable parts, such as rubber accessories, castors and grips, which are subject to normal wear and tear and require periodic replacement.

If you have any queries please contact CareCo.

The manufacturer reserves the right to alter without notice any weights, measurements or other technical data shown in this manual. All figures, measurements and capacities shown in this manual are approximate and do not constitute specifications.