

Electric Circulation and Muscle Exerciser

Product Code: DLO4040001

Thank you for purchasing your Pedal Exerciser with Digital Display. This is designed to help improve circulation and muscle strength and is ideal for those who want to exercise in the comfort of their own homes. It is manufactured from the finest quality materials, and when used correctly will last for years to come.

Before Use

Remove all packaging carefully and check that all parts are present and correct. If there are any signs of damage, contact your supplier.

Warnings

- Read this manual carefully before use, retain for your reference and ensure anyone else using the product refers to it.
- Ensure the mains socket is compatible with the product before use - the holes in the socket must match to the pin configuration of the plug. If there is any difference, please contact your supplier.
- Ensure the product is plugged into the mains before switching the power on.
- Only use indoors.
- Always unplug the unit after use - do not leave plugged in and unattended.
- Only use on a firm flat surface and ensure there is sufficient free space surrounding the unit.
- Regularly inspect the product for any signs of damage - if any appear stop using and contact your supplier immediately.
- Do not use in the bathroom, or anywhere damp or wet.
- Consult a medical professional before use.
- As with all exercise, do not proceed if you feel unwell or immediately after eating. Ensure you have warmed up and cooled down sufficiently.
- Ensure suitable clothing and footwear are worn at all times.
- Do not allow children to play with this appliance - it is suitable for use by people of 8 years and above and people with reduced physical, sensory or mental capabilities if they are supervised or instructed correctly.
- Ensure leads are not obscured by carpets or rugs, and take care that the cable does not come into contact with the pedals.

Components and Fixings

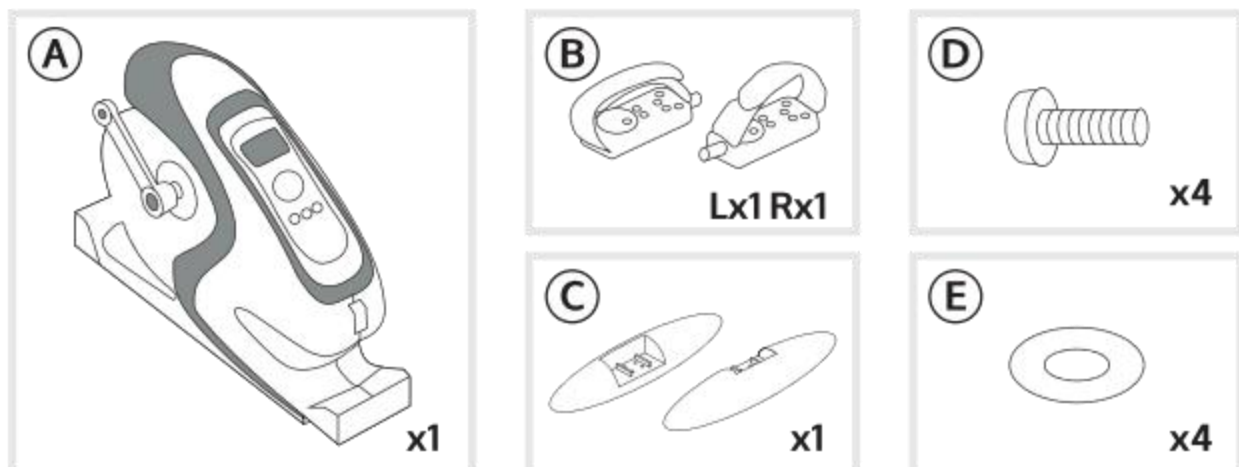

Assembly

1. Fitting the Stabilisers

Secure the front stabiliser (marked with the letter A on it), with 4 screws and washers as shown in diagram to the right.

Repeat the same process with the rear stabiliser (marked with the letter B1 on it).

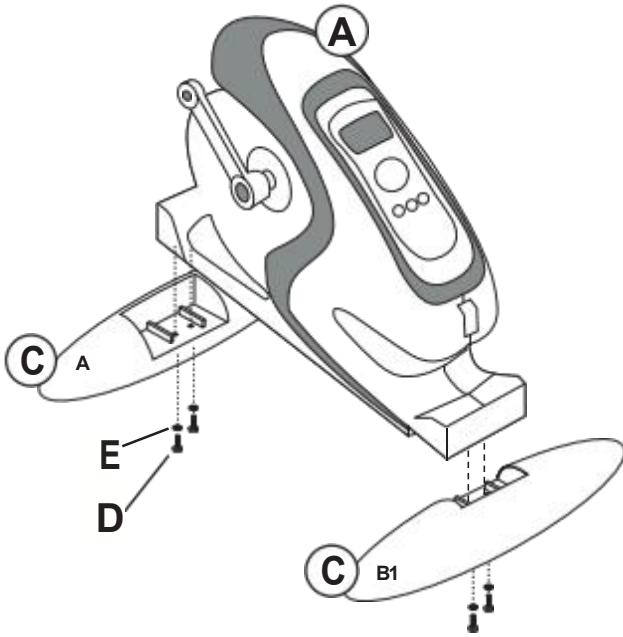

2. Attaching the Pedals

Attach the Left hand Pedal (B) marked with L on it into the left hand crank (also marked with an L) using the included spanner. Repeat this process for the right hand pedal.

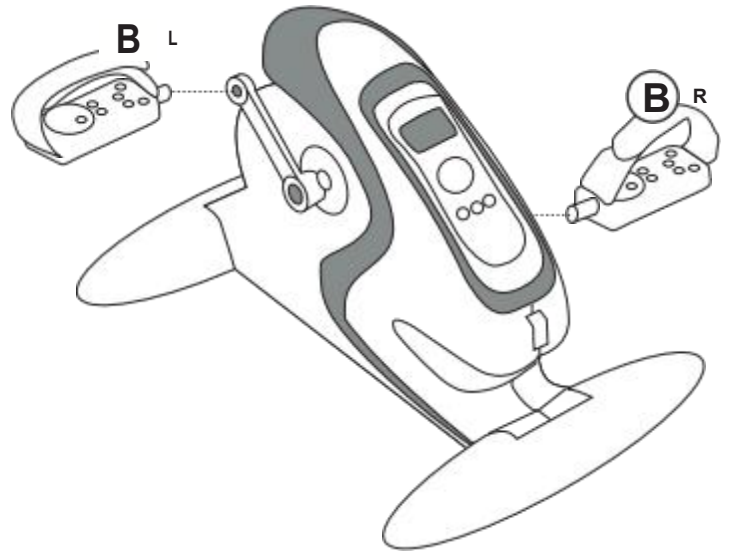

Remote Control

1. Power On/Off
2. Time (Time selection button; 1-15 min)
3. Decrease Speed (12 settings)
4. Increase Speed (12 settings)
5. Forward/Reverse (Pedal direction)
6. Mode (Press to display speed, time, distance or calories)

Please Note:

To **increase the time** press and hold the time button.
To **increase the speed** press and hold the speed button.

Power On/Off

To **Power On** plug the power socket into the wall outlet. Switch the main power button to position I (located below the remote control).

To switch the machine on press the red power button (1) on the remote control.

To **Power Off** reverse the above process.

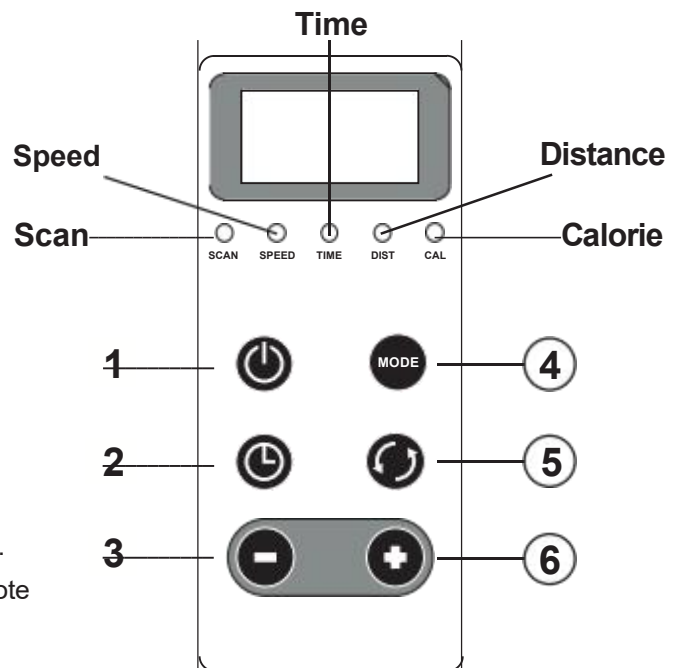

Exercises

Seated

- Use a stable chair with the unit placed at a comfortable distance away so you don't overstretch your legs.
- Use a cushion for support to the lower back.
- Sit in the chair with your feet on the pedals and switch the unit on.
- Follow the instructions for using the remote control until you reach the desired setting, then proceed with the desired programme.

Seated

- Ideally lie down on a mat to protect your back from the hard floor - use a cushion to support the lower back.
- Place the unit a comfortable distance away to avoid over-stretching your legs, place your feet on the pedals, and switch the unit on.
- Follow the instructions for using the remote control until you reach the desired setting, then proceed with the desired programme.
- When you have finished, remain on your back for a few minutes before getting up slowly to avoid any dizziness.

Upper Body

- Place the unit on a table or similar stable surface so that it is level with your chest, and sit on a stable chair facing towards it.
- Ensure the unit is placed at a comfortable distance away to avoid overstretching the arms.
- Follow the instructions for using the remote control until you reach the desired setting, then proceed with the desired programme.

Cleaning

Always ensure the unit is switched off and unplugged before cleaning. Only use a non-abrasive cleaner or mild detergent with a soft cloth to avoid damage to the unit. Wipe dry after cleaning.

Maintenance

Make regular safety checks on this product, paying particular attention to the fastening elements and the cables/wires. If there are any issues do not use the unit and contact your supplier immediately.

PAT Testing

This product must be PAT tested yearly for use in a workplace, this is also recommended for us in a domestic setting.

